



THERM-A-HINGE / THERM-A-LOCK

A cost effective method of protecting fire door locks and hinges

INTRODUCTION

It has been proved conclusively that the ironmongery fitted to fire doorsets with ratings over FD30 introduces a great weakness to the door's overall performance unless some additional protection is applied over and above that afforded by the normal door edge intumescent strip.

Time and time again, doorsets fail fire performance tests. This is due to premature burn through by the upper and mid-height hinge positions, and whilst this has been recognized officially in BS8214 (1990), there has been no specific guidance offered to specifiers and installers as to what type of intumescent materials to employ.

Pastes and mastics are messy and it is difficult to control the rate of application, plugs are time consuming to fit and the normal 15 or 20 x 4mm seals do not have the extra volume of material required for satisfactory performance.

THERM-A-HINGE & THERM-A-LOCK, offers a tailored solution to the problem of providing a pre-sized backing pad of intumescent material fitting behind the hinge blade and around the lock set.

DESCRIPTION

THERM-A-HINGE & THERM-A-LOCK pads are produced from an exclusive LP material developed as a low pressure intumescent to withstand a full range of environmental conditions and flexible in nature for ease of installation. The material can be manufactured either 1mm or 2mm thick and can be supplied in lengths or pre-cut to match any hinge or lock.

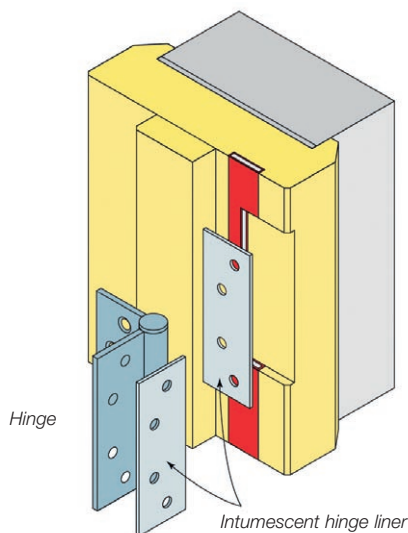
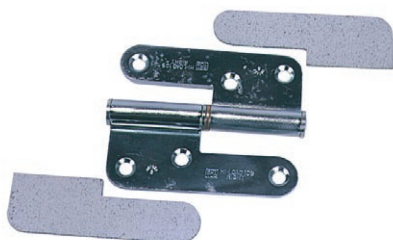

INSTALLATION

THERM-A-HINGE pads should be under hinges on all fire doorsets with a rating of over 30 minutes, the rebate in door edge and frame should be cut 1 or 2mm deeper than normal, to enable the pad to be placed under the hinge blade, with the hinge then ending flush with the timber.

The THERM-A-HINGE pads are fitted under both blades of the hinge and are simply trapped between hinge and timber, fixing screws can simply be driven through the intumescent material. NO adhesives or sealants are required.

THERM-A-LOCK should wrap around the lock assembly like a 'jacket' before inserting into the door leaf. The self adhesive backing and pre-cut sets enable a quick & easy process of installation. No other adhesives or sealants are required.

PERFORMANCE

The fire performance of THERM-A-HINGE backing pads has been proven many times in full-scale BS476 part 22 (1987) fire tests on doorsets of 60 minutes construction. Test reports are available on request.

LOCK & LATCH PROTECTION

These provide fire resistance of 30 minutes or 60 minutes when fitted to full size door assemblies and tested in accordance with BS 476 Pt. 22.

We can supply intumescent sleeves to fit all regular UK lock case sizes of 63mm, 75mm and 100mm deep with a common height of 108mm and 56mm centres, generally manufactured to the dimensions given in BS 5872: 1980 figure 4. Other sizes can be provided: please refer to our Technical Department.

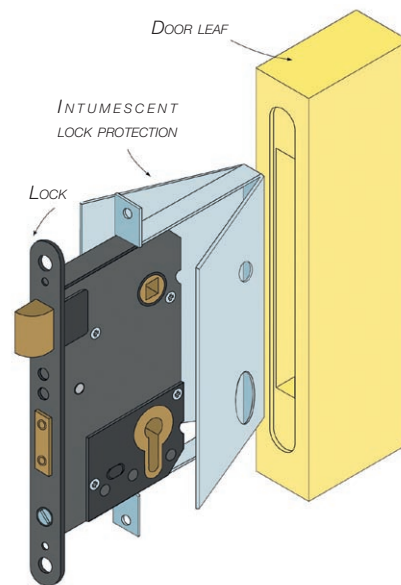

AVAILABILITY

THERM-A-HINGE backing pads are stocked in the following sizes;

- 30mm x 100mm
- 32mm x 100mm
- 36mm x 100mm
- 48mm x 100mm

Supplied 1mm and 2mm thick self adhesive.

THERM-A-LOCK pads are stocked in the following sizes;

- 130mm x 2100mm
- 165mm x 85mm x 16mm

Supplied 1mm thick self adhesive.